



INTAKE SYSTEMS FOR VEHICLES LISTED ARE 50 STATE LEGAL. SEE KNFILTERS.COM FOR CARB STATUS ON EACH PART FOR A SPECIFIC VEHICLE.

INSTALLATION INSTRUCTIONS

57-9021
TOYOTA
1999-05 Land Cruiser
V8-4.7L DOHC

NOTE: This kit was not designed to fit vehicles with a body lift.

TOOLS NEEDED:

- 10mm Wrench
- 13mm Wrench
- 5/8 Wrench
- Ratchet
- Extension
- 1mm Socket
- 12mm Socket
- 13mm Socket
- Flat Blade Screwdriver
- Phillips Screwdriver
- 4mm Allen Wrench
- 2.5mm Allen Wrench

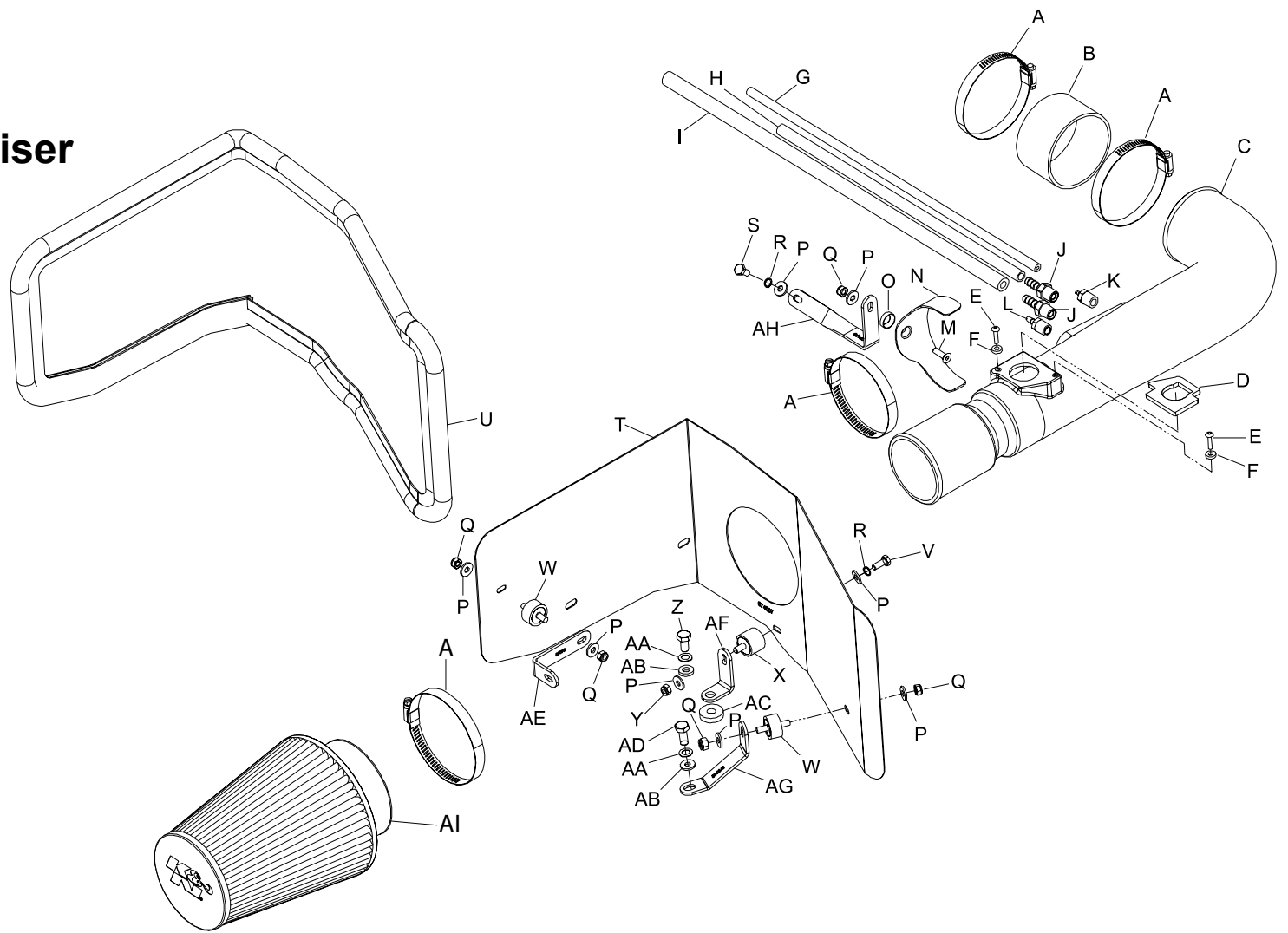

PARTS LIST:

Description	Qty.	Part #	Description	Qty.	Part #	Description	Qty.	Part #
A HOSE CLAMP; #52	4	08610	M BOLT; M6-1.00 X 20MM	1	08376	Y NUT; 1/4"-20, NYLOCK	1	07517
B HOSE; 3.25"ID X 2"L	1	08690	N BRACKET; SADDLE	1	078855	Z BOLT; 8MM-1.25 X 20MM	1	07787
C INTAKE TUBE; (CZ)	1	087094A	O WASHER; NYLON	1	08180	AA WASHER; 8MM SPRING	2	08239
D GASKET; 3/16" PORON	1	09026	P WASHER; 1/4"ID X 5/8"OD	8	08275	AB WASHER; 5/16"ID X 5/8"OD	2	08276
E SCREW; M4-.7 X 16MM	2	07793	Q NUT; 6MM NYLOCK	5	07553	AC WASHER; 1"OD X .37"ID	1	08281
F SPACER; .437"OD X .200"ID	2	06503	R WASHER; 1/4" LOCK	2	08198	AD BOLT; 8MM-1.25 X 16MM	1	07844
G HOSE; 4MM ID X 18"L	1	08153	S BOLT; M6-1.00 X 16MM	1	07703	AE BRACKET; "L"	1	07093
H HOSE; 8MM ID X 15.5"L	1	08105	T HEAT SHIELD	1	074007	AF BRACKET; "L"	1	070712A
I HOSE; 8MM ID X 21"L	1	08409	U EDGE TRIM; 70"L	1	102454	AG BRACKET; "C"	1	070782
J FITTING; 5/16", 1/4 NPT	2	08908	V BOLT; 1/4-20 X 1/2"	1	08317	AH BRACKET; "L" LG.	1	07178
K VENT; 1/8 HOSE, 1/4 NPT	1	08052	W STUD; M6-1.00 RUBBER	2	07027	AI AIR FILTER	1	RU-5100
L FITTING; 1/4" NPT, 3/16 BARB	1	080021	X STUD; 1/4-20 RUBBER	1	070226			

NOTE: FAILURE TO FOLLOW INSTALLATION INSTRUCTIONS AND NOT USING THE PROVIDED HARDWARE MAY DAMAGE THE INTAKE TUBE, THROTTLE BODY AND ENGINE.

TO START:

1. Turn off the ignition and disconnect the negative battery cable.

NOTE: Disconnecting the negative battery cable erases pre-programmed electronic memories. Write down all memory settings before disconnecting the negative battery cable. Some radios will require an anti-theft code to be entered after the battery is reconnected. The anti-theft code is typically supplied with your owner's manual. In the event your vehicles' anti-theft code cannot be recovered, contact an authorized dealership to obtain your vehicles anti-theft code.



2. Remove the two bolts and two nuts that secure the engine cover, then remove the engine cover.



3. Disconnect the mass air sensor electrical connection and mass air sensor wire harness, retaining clip from the air box.



4. Remove the four vent lines from the air intake resonator as shown.

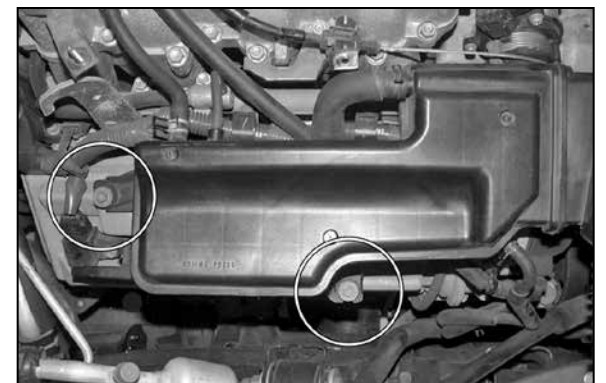

5. Remove the two bolts that secure resonator assembly to the motor.

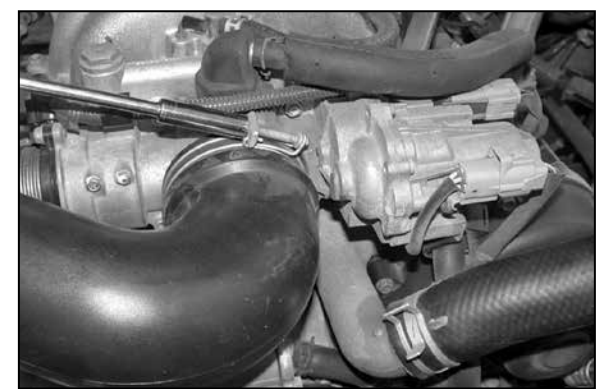

6. Loosen the hose clamp at the throttle body as shown.

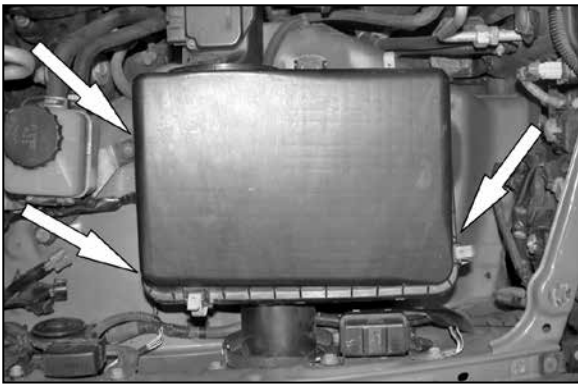

7. Loosen the three bolts that secure the air cleaner assembly to the inner fender.



8. Remove the intake tube from the throttle body, then remove the complete air intake assembly.
NOTE: K&N Engineering, Inc., recommends that customers do not discard factory air intake.

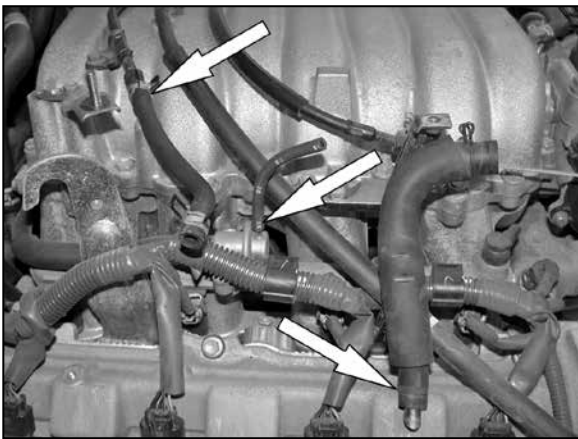

9. Remove the EVAP canister vent hose, the crank case vent hose and the fuel pressure regulator vent hose.

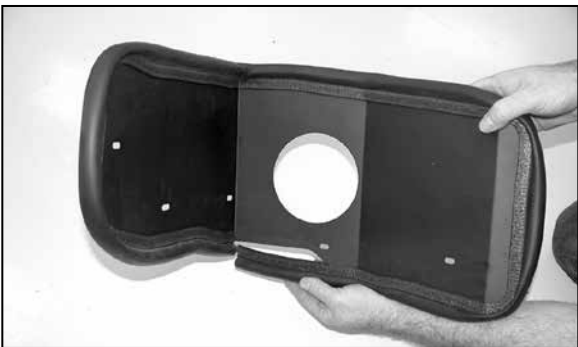

10. Apply the edge trim to the heat shield as shown above. Trim excess as needed.

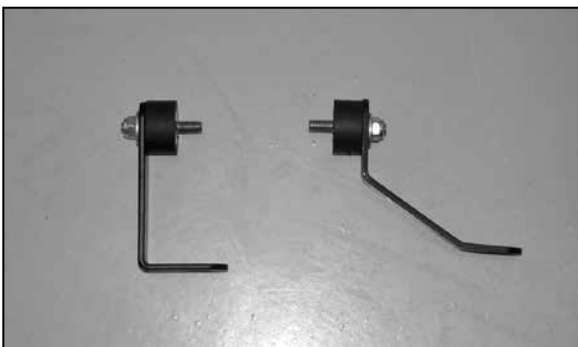

11. Assemble the rubber mounted studs onto the brackets as shown.



12. Assemble the 3/4" tall rubber mounted stud to the "L" bracket as shown.

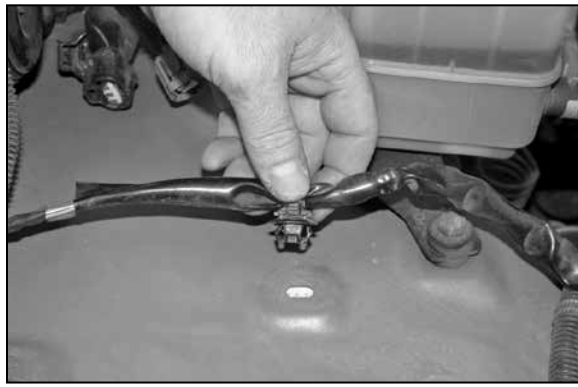

13. Remove the mass air wire harness clip from inner fender.



14. Install small "L" bracket with 3/4" rubber mounted stud to the inner fender as shown with provided nylon spacer and hardware.



15. Install bracket (070782) with rubber mounted stud onto vehicle with provided hardware.



16. Remove 10mm bolt securing fresh air duct and install bracket (07093) onto vehicle with bolt that was removed.



17. Install the heat shield onto vehicle with provided hardware.



18. Insert mass air wire retaining clips into holes provided in heat shield.

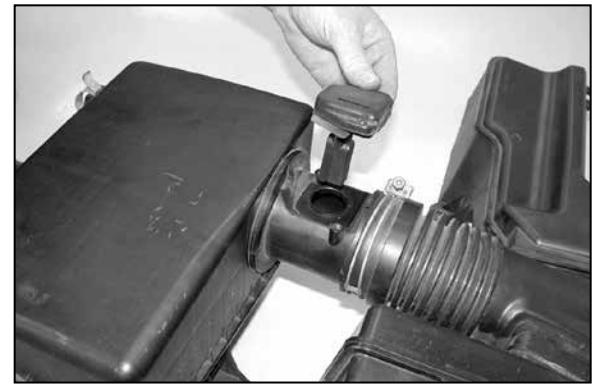

19. Remove two screws securing mass air sensor to stock intake tube, then remove mass air sensor from tube.

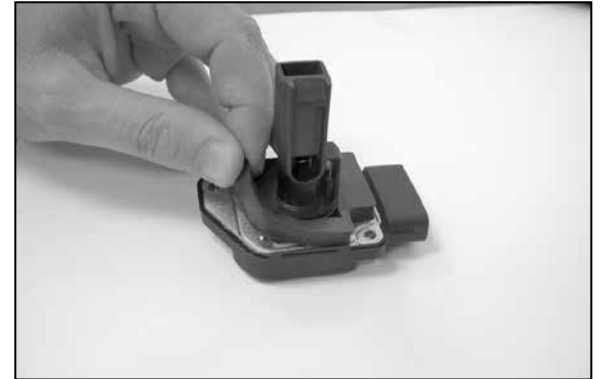

20. Install provided gasket sticky side down as shown.



21. Install provided npt vent fittings onto tube as shown.

NOTE: Plastic NPT fittings are easy to cross thread. Install the vent fitting "hand" tight, then turn it two complete turns with a wrench.



22. Install mass air sensor onto tube with provided bolts and nylon spacers as shown.



23. Assemble the saddle bracket assembly with provided hardware as shown.



24. Install saddle bracket assembly onto cam cover with provided hardware.



25. Install silicone hose (08690) onto throttle body with provided hose clamps as shown.



26. Install the K&N® intake tube onto the throttle body and align the tube with the saddle bracket, then tighten all hose clamps to secure intake tube.

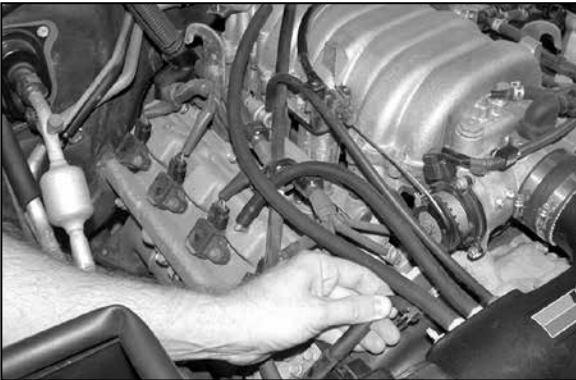

27. Install the three provided vent hoses in place of the vent hoses removed in step #9, and connect them to the vent fittings in the K&N® intake tube. Also re-connect the one existing vent hose to the vent fitting.

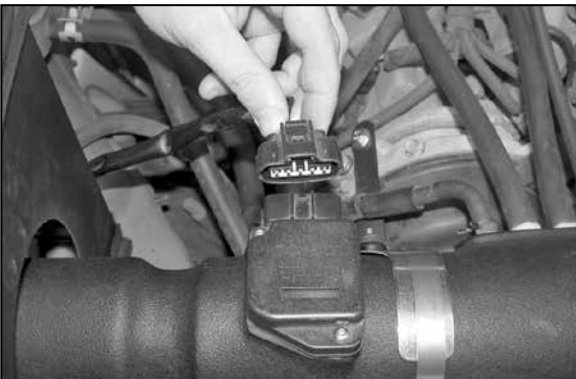

28. Re-connect the mass air sensor electrical connection.

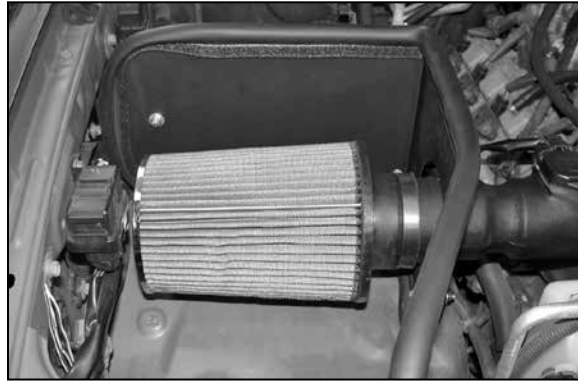

29. Install the K&N® air filter onto the K&N® intake tube as shown.

NOTE: Drycharger® air filter wrap; part # RC-5100DK is available to purchase separately. To learn more about Drycharger® filter wraps or look up color availability please visit <http://www.knfilters.com>®.



30. Reinstall the engine cover with hardware removed in step #2.



31. Reconnect the vehicle's negative battery cable. Double check to make sure everything is tight and properly positioned before starting the vehicle.

32. The C.A.R.B. exemption sticker, (attached), must be visible under the hood so that an emissions inspector can see it when the vehicle is required to be tested for emissions. California requires testing every two years, other states may vary.

33. It will be necessary for all K&N® high flow intake systems to be checked periodically for realignment, clearance and tightening of all connections. Failure to follow the above instructions or proper maintenance may void warranty.

ROAD TESTING:

1. Start the engine with the transmission in neutral or park, and the parking brake engaged. Listen for air leaks or odd noises. For air leaks secure hoses and connections. For odd noises, find cause and repair before proceeding. This kit will function identically to the factory system except for being louder and much more responsive.

2. Test drive the vehicle. Listen for odd noises or rattles and fix as necessary.

3. If road test is fine, you can now enjoy the added power and performance from your kit.

4. K&N Engineering, Inc., requires cleaning the intake system's air filter element every 100,000 miles. When used in dusty or off-road environments, our filters will require cleaning more often. We recommend that you visually inspect your filter once every 25,000 miles to determine if the screen is still visible. When the screen is no longer visible some place on the filter element, it is time to clean it. To clean and re-oil, purchase our filter Recharger® service kit, part number 99-5050 or 99-5000 and follow the easy instructions.

INTAKE SYSTEMS FOR VEHICLES LISTED ARE 50 STATE LEGAL. SEE KNFILTERS.COM FOR CARB STATUS ON EACH PART FOR A SPECIFIC VEHICLE.